

## OPERATING INSTRUCTION

carbone dioxide sensor

**GAS SENSOR GMF 775 IR CO2 VA**  
with stainless special steel housing



**GMF 775 IR**

### Attention!

Read and understand all the instructions before you start working.

### Due application

This sensor device measures carbone dioxide in the air.  
The application is for to detect leakages and/or monitoring the TLV Level  
It forms a standard output 4...20 mA current signal.

### Sensoric

The sensitive element of this measuring device is an long live infrared sensor especially for carbone dioxide

### Assembly

This unit is to be installed wall mounted in 0,2..0,4 m height.

### Connection to a gaswarning unit

The supply voltage ranges between 12...35 Volt DC.

Use shielded 4-wire cable JY(St) 2x2x0.8mm. The wires can be assigned as follows:  
red => +24V (KI 1), white => 4-20mA (KI 2), black => not connected,  
drill the shield wire on the yellow wire => screw on metal sensor case  
Make sure, that the non isolated shield wire doesn't touch the electronic circuit.

At the gas warning central also drill the shield wire on the yellow wire  
and both must be connected to clamp 4 (PE) at the gas warning central.  
But do **not** connect the shield wire and the yellow wire to clamp 4 at the gas warning central  
**if the sensor unit is mounted on an iron or steel girder.**

## Adjusting the output signal

Do not adjust this unit before 1 hour after power on.  
The probe gas must be tempered to the surrounding air, as well as the measuring unit.

### Equipment

Multimeter 0-20 V  
Screw driver  
Zero gas can (synth. air)  
Calibration gas can (approx. 50% ..100% of measuring range CO<sub>2</sub>)  
Flow control valve, flow meter 0..1 liter/minute)  
gas exposing adaptor

### Zero point adjusting

The sensor must be exposed to zero-gas (synthet. air without CO<sub>2</sub>) with a flow rating ~ 0,2 liter/minute.

1. Put the switch to the upper position for to see also negative sensor offset at MP1
2. Adjust trimmer „P1“ so, that you can read a voltage of 0,4 Volt at **MP1**.  
So your output signal will be 4 mA.

### Span adjusting

3. The sensor must be exposed to carbone dioxide gas (approx. 5 Vol%) with a flow rating ~ 0,2 liter/minute.
4. adjust trimmer „P2“ to a special reading on **MP1**. The reading must be calculated as follows:

$$\text{Reading MP1} = 1,6 \text{ Volt} * \text{gas-concentration}/5 \text{ Vol\%} + 0.4 \text{ Volt} \quad (\text{if measuring range} = 5 \text{ Vol\%})$$

for example: a gas probe with 1,5 Vol% carbone dioxide must give a reading of 0,88 Volt.  
This refers to an output current of 8,80 mA.

5. Put the switch back to the lower position for normal operation

### Place plan GMF 775 IR

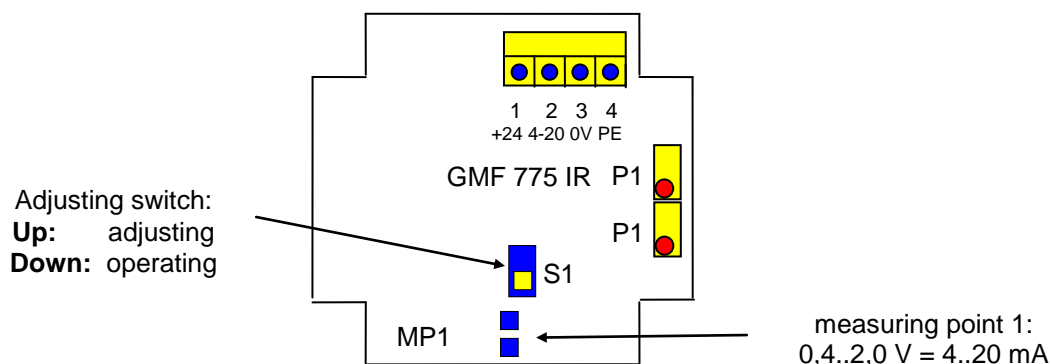

## Start-up

The correct setting of the output signal is to be controlled by exposing the measuring unit to an well-known gas concentration. The setting of alarm points at the gaswarning unit is to be controlled.

## Maintenance

The sensor needs maintenance and adjusting at least every year.

## Putting out of operation

Is the sensor out of operation for more than 4 weeks, the sensor needs calibration before it can be used correctly.

## Technical data

Measuring principle:	Infrared absorption, 2 wavelenghts
Type of gas:	carbone dioxide
Measuring range:	0..1000/5000/10000 ppm, 0...5/10/20/100 Vol% factory set
Measuring accuracy:	<+-1% of measuring range
Display:	none
Starting time:	< 60 secondes
Response time T90:	< 60 secondes
Temperature range:	-20..+50°C (environment)
Humidity range:	0..100% relative humidity
Pressure range:	700-1300 hPa
Housing:	stainless special steel, LxWxD: 110x90x80 mm
Protection type:	IP68
Gas entry:	diffusion
Protective components:	hydrophobic and oleophobic teflon-membrane
Output signal:	4-20 mA, linear
Max. load:	500 R
Durability:	>5 years of operation
Storage time:	> 2 years
CE-conformity:	emission: living area, immunity: industrial area
Weight:	450 g
Supply:	12-35V DC
Power consumption :	max. 2 W
Connecting cable:	up to 500 m: JY (ST) Y 2x2x0,8 mm

November 2008

Technical changes reserved